



D5.3

Report on Tests in Controlled Environment



This project has received funding from the European Union's Horizon 2020 research and innovation programme under grant agreement N. 953432.

The content of this deliverable does not reflect the official opinion of the European Union. Responsibility for the information and views expressed therein lies entirely with the author(s).

WP5 Tests and Evaluation

D5.3 Report on Tests in Controlled Environment

Contract number:	953432
Project acronym:	FitDrive
Project title:	Monitoring Devices for Overall Fitness of Drivers
Planned delivery date:	M28 (Dec 2023)
Leading partner:	AIPSS
Partners contributed:	ITCL, ROMATRE, UNISAP, SECURETEC, ASELSAN
Document date:	20/12/2023
Version:	2
Subversion:	3
Deliverable type:	Report
Remarks:	This deliverable summarises the activities conducted during the tests of Pilot Cycle 2 in controlled environment.
Status:	<input checked="" type="radio"/> PU (Public) <input type="radio"/> PP Restricted to other programme participants (including the Commission Services) <input type="radio"/> Restricted to a group specified by the consortium (including the Commission Services) (please specify the group) <input type="radio"/> Confidential, only for members of the consortium (including the Commission Services)

Document Revision Log

Version	Subversion	Date	Description	Author
0	1	30/10/2023	Deliverable scheme	Maddalena D'Amore (AIPSS)
0	2	09/11/2023	Preliminary content	Carlo Polidori, (AIPSS)
0	3	23/11/2023	First deliverable draft	Carlo Polidori, (AIPSS)
0	4	30/11/2023	Content added	Marco Petrelli, Simone Sportiello (ROMATRE) Carlo Polidori (AIPSS)
1	0	07/12/2023	Full version	Carlo Polidori (AIPSS)
1	1	14/12/2023	Dashboard images added and text corrections	Manuel Ramiro (ADSYS)
1	2	17/12/2023	Internal review	Gianluca Di Flumeri (UNISAP)
1	3	17/12/2023	Internal review	Stefan Ringlstetter (Securetec)
2	0	18/12/2023	Corrections after revision	Carlo Polidori (AIPSS)
2	1	19/12/2023	Review & formatting	Marteyn van Gasteren (ITCL)
2	2	20/12/2023	Minor updates on tachograph	Sefa Kalaycı (ASELSAN)
2	3	20/12/2023	Final review & formatting	Marteyn van Gasteren (ITCL)



Executive Summary

This report details the activities and outcomes of Work Package 5 (WP5), which focuses on organizing and executing controlled environment and naturalistic tests to validate the results attained in Work Package 2 (WP2), obtained in simulated conditions, by deploying the ICT framework developed in Work Package 4 (WP4). The report covers the test Cycle 2 (C2) involving truck drivers in Spain and van drivers in Italy.

The previous Cycle 1 (C1) involved simulated driving tests for 16 truck drivers in Spain and 16 van drivers in Italy. Subsequently, eight drivers from each category were selected for real driving tests in controlled environments. A deviation from the initial plan occurred when the decision was made to concentrate efforts on two key drivers' categories: truck drivers, and van drivers delivering parcels in urban areas.

The locations selected for the tests in Italy (Rome) and Spain (Villatoldanos, León) provided controlled environments for conducting adaptation, high mental load, and monotonous tasks. Devices used for data collection included those measuring neurophysiological parameters of drivers and those capturing vehicle data, such as a "BridgeBox" and a "smart tachograph".

The second cycle of tests (C2) involved volunteer engagement, safety measures, and privacy considerations. Tests in Italy and Spain were conducted, with the former taking place in May 2023 and the latter experiencing some delays due to integration issues of BridgeBox with the truck data Systems. and finally performed in October 2023. Specific effort was dedicated to successfully overcome compatibility issues with truck data systems.

Despite the challenges, all tests were successfully conducted, and the results are detailed in the confidential deliverables D2.6, (C1) and in the upcoming deliverable D3.2 (C2). The report concludes that the tests were completed according to plan, with valuable insights gained for future phases, and emphasizes the importance for the next Cycle 3 of timely data transmission through the cloud for prompt intervention in case of device issues.

Overall, the findings from this phase contribute to the ongoing development of the FitDrive project and its goal of enhancing road safety through advanced driver monitoring and analysis.

1. Contents

1. Contents	5
2. Introduction	7
3. From C1 to C2 tests	8
3.1. Test location in Italy (Rome)	8
3.2. Test location in Leon (Spain).....	9
4. Test Devices	10
5. Data transmission in Cloud	12
6. C2 tests conduction	13
6.1. Volunteer engagement, safety measures and privacy	13
6.2. C2 test in Italy	13
6.3. C2 test in Spain	16
7. Test results	20
8. Conclusions	21



List of Figures

Figure 1: Pilot Cycle 1 and 2 summaries.	7
Figure 2: Aerial image of the Fiera with the two available areas marked in blue (Fiera complex) and red (kart circuit).	8
Figure 3: Aerial image of the abandoned urbanization area in Valladolid.	9
Figure 4: The blue and red routes chosen for the tests in Leon.	9
Figure 5: Devices for measuring the driver’s neurophysiological data (picture taken during the C2 tests in Spain).	10
Figure 6: Devices for measuring the vehicle data.	11
Figure 7: Scheme of the cloud-based data transmission.	12
Figure 8: Dashboard of the control system for the data transmitted by the vehicles.	12
Figure 9: Van used for the C2 tests in Italy.	13
Figure 10: Wearing the measurement devices before the C2 tests in Italy.	14
Figure 11: Real-time neurophysiological parameters, specifically the EEG activity in the first 8 channels, the PPG signal (heart activity) in the 9th channel, and the EDA measurement (alias GSR, skin sweating) in the last channel, during the C2 tests in Italy.	14
Figure 12: High demanding task (kart circuit) during the C2 tests in Italy.	15
Figure 13: Dashboard with van data.	15
Figure 14: preliminary test in controlled environment in Spain.	16
Figure 15: Truck rented for the C2 tests in Spain.	17
Figure 16: Volunteer driving the truck during the C2 test in Spain.	17
Figure 17: Statement given to the Truck driver explaining the use of the Smart Tachograph.	18
Figure 18: Dashboard controlling Trucks.	19
Figure 19: Example of truck data monitoring.	19

2.Introduction

The objective of WP5 is to organize and deploy a series of controlled environment and naturalistic tests to validate the results obtained in WP4, as well as to recruit the needed volunteers for the real-life tests and demonstration. The first two test cycles are strongly connected, as shown in the picture: in the first cycle 16 truck drivers in Spain and 16 van drivers in Italy performed a simulated driving test (described in deliverables D2.4 and D2.5), then 8 of them have been selected for real driving tests in controlled environments (Task 5.2) that are described in the following sections. The second test cycle started in month 18 and was concluded in month 27; a deviation from the DoA consists in the change of drivers' type, originally divided into professional goods vehicle drivers, professional passenger vehicle drivers, taxi drivers, van drivers, and non-professional car drivers. After several discussions and literature analysis, it appeared clear that such "granularity" was counter-productive in term of reliability of data to be gathered, due to the limited number of specific testers. During the first consortium meeting CM1, the consortium agreed to concentrate the efforts towards the two most relevant drivers' categories: 1) truck drivers and 2) van drivers delivering parcels in urban areas.

	1 st CYCLE (Task 2.4)	2 nd CYCLE (Task 5.2)
COUNTRY	ITALY / SPAIN	ITALY / SPAIN
METHOD	SIMULATION	CONTROLLED ENVIRONMENT
ENVIRONMENT	MULTIUSER CAR AND TRUCK SIMULATOR 	SPAIN: E2N ROAD (OPEN TO VEHICLES) ITALY:ACI-GUIDA SICURA TEST SITE
USERS	16 Truck/Bus drivers (Spain) 16 Van drivers (Italy)	8Truck/Bus drivers (Spain) (1) 8 Van drivers (Italy) (2)
PERIOD	M9-M14; M17-M20	M16-M24
TESTS PROCEDURE	DRIVE IN THE SIMULATOR WEARING NEURO-DEVICES AT THE END OF THEIR USUAL WORKING DAY IN THREE ROUNDS OF 20 MINUTES EACH FOR A TOTAL OF 1 HOUR 	DRIVE 1 HOUR IN THE EVENING AT THE END OF THEIR USUAL WORKING DAY WEARING NEURO-DEVICES AND DRIVING IN A PREDESIGNED CIRCUIT.
SENSORS USED	EEG/ GSR / ECG/ PPG /EMPATICA E4 / EYE TRACKER/ LIGHTING. TEMPERATURE. RELATIVE HUMIDITY AND AIR QUALITY SENSORS	EEG/ GSR / ECG / PPG /EMPATICA E4 / EYE TRACKER / LIGHTING. TEMPERATURE. RELATIVE HUMIDITY AND AIR QUALITY SENSORS
VEHICLE CONFIGURATION	TELEMETRY SYSTEM THAT RECORDS (SPEED, RPM, USER FACE, GAZE TRACKER, GEAR...). ENVIRONMENT INFORMATION TTC TO THE NEAREST VEHICLE, VRU DISTANCE... AND VIDEOS ARE RECORDED.	GEOLOCATION (GNSS/GPS). SPEED. STEERING WHEEL. PEDALS. WHEELS. BINNACLE (XEE BOX AND TACHOGRAPH ACTUAL DEVELOPMENT)
DATA ANALYZED	FATIGUE NEUROMETRICS MENTAL STATE 	FATIGUE NEUROMETRICS MENTAL STATE

Figure 1: Pilot Cycle 1 and 2 summaries.

3. From C1 to C2 tests

As already explained in previous deliverables (D2.4 and D2.5), the cycle 1 tests were carried out by reproducing on the simulator the physical circuit in which the same volunteers would actually drive during cycle 2; therefore, during the project, the physical places for the naturalistic guide were first identified which would allow the three tasks envisaged by the protocol to be carried out (an **adaptation task**, an **highly engaging task**, and a **monotonous task**). Then the simulation environment was built for the location in Italy and Spain. The rationale of the experimental design has been provided into D2.5. It has to be noted that the test sites were chosen in order to provide similar road infrastructure, i.e. straights alternating with 90-degree turns, more realistic than traditional racetracks (initially suggested in the DoA) in replicating drivers' daily experience.

The selection in Italy and Spain of the 8 volunteers among the 16 who carried out the C1 test was carried out taking into account driving stability and other factors that could guarantee the best data collection for subsequent machine learning applications.

3.1. Test location in Italy (Rome)

The location chosen for C1 and C2 in Italy (was the New Fiera di Roma, a private complex normally used for fairs and expositions. Since it's closed to public traffic, it is a controlled environment in which tests have been safely conducted.



Figure 2: Aerial image of the Fiera with the two available areas marked in blue (Fiera complex) and red (kart circuit).

The blue marked area is the general Fiera complex, and the red-marked area is a small kart circuit adjacent to it. The complexity and narrowness of the circuit has been used for the high demanding task, while the straight and wide roads of the complex are a good choice for the monotonous task.

3.2. Test location in Leon (Spain)

The location chosen for C1 and C2 in Spain is an abandoned urbanization in Villatoldanos, León. Despite being a public road, there is no traffic since there are no buildings and the city council closed off the roads during the experiments, so these were performed in a controlled environment. Being a squared road network, different exercises have been organized for the three planned tasks.



Figure 3: Aerial image of the abandoned urbanization area in Valladolid.

In particular, an almost “circular route” has been designed for the monotonous task (blue arrows in fig.4) and a route with several turns was chosen for the high demanding task (red arrows)

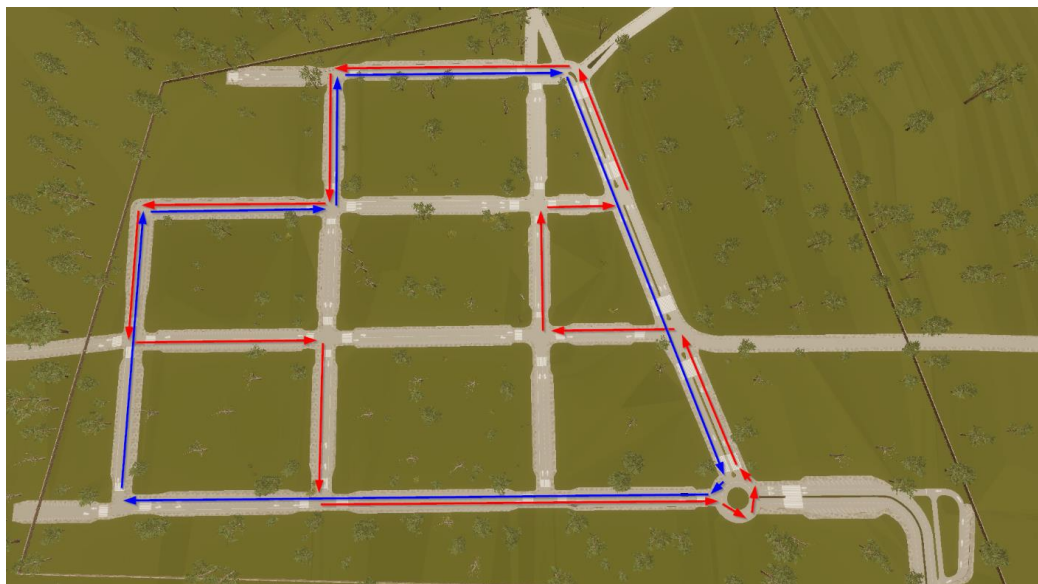

Figure 4: The blue and red routes chosen for the tests in Leon.

4. Test Devices

There were two groups of devices: the first one focused on parameters able to define the neurophysiological status of the driver, and the second one focused on vehicle data.

The list of devices and data measured is shown in Figure 5:



Figure 5: Devices for measuring the driver's neurophysiological data (picture taken during the C2 tests in Spain).

The second group of devices measured the data coming from the vehicles: they are a “BridgeBox” able to read vehicles data and a “smart tachograph”.

	Device	Measurement
	BridgeBox	Vehicle data
	Smart Tachograph (trucks only)	Vehicle data & Driver card data

Figure 6: Devices for measuring the vehicle data.

5. Data transmission in Cloud

Vehicle’s data collected during the tests were transmitted in cloud; such a transmission will become relevant in the future cycle 3 tests, where the drivers are expected to drive for one month “as usual” during their working hours; in general, during the C3 test, they may avoid having contacts with the project staff, but a continuous monitoring is necessary to check the correctness of the data gathered. To this purpose, the partner ADSYS developed a cloud-based system able to check every few seconds the connectivity and correctness of the transmission. In case of simple issue (e.g. battery exhausted) the driver could fix them through instructions given by phone; for more complex situation, the driver will be asked to come back to the garage. In Cycle 2 tests the system has been successfully validated.

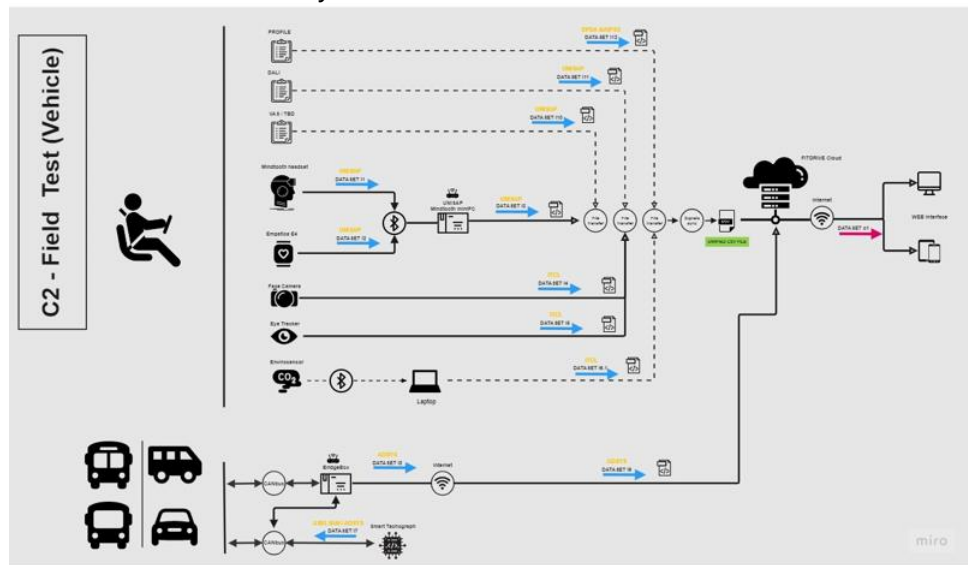

Figure 7: Scheme of the cloud-based data transmission.

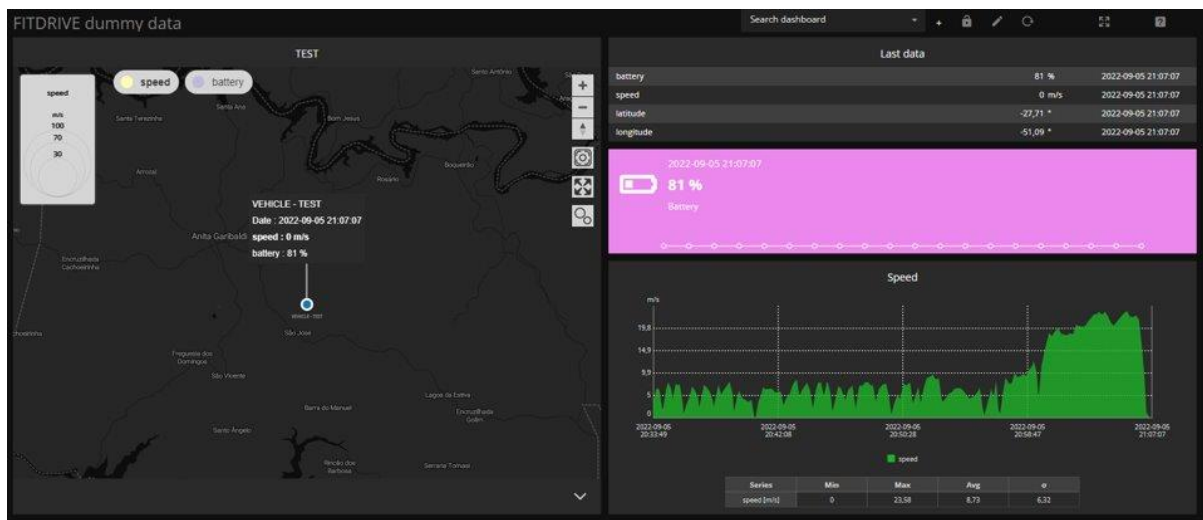

Figure 8: Dashboard of the control system for the data transmitted by the vehicles.

6. C2 tests conduction

6.1. Volunteer engagement, safety measures and privacy

The C2 volunteers are a restricted group selected from the volunteers already engaged in C1 test.

All the safety and privacy respect measures are described in the public deliverable D5.2 “Test operation Manual”.

6.2. C2 test in Italy

The C2 Tests in Rome were conducted during the week 8-12 May 2023 in the chosen location Fiera di Roma. Nine out of sixteen C1 volunteers were selected on the basis of the quality of the data recorded during the Cycle 1 (8 as planned plus one reserve).

The list of the data set obtained is reported hereinafter, with the volunteers indicated through their anonymous code already adopted during the Cycle 1 tests.

c2ituser001
c2ituser002
c2ituser012
c2ituser013
c2ituser014
c2ituser015
c2ituser016
c2ituser019

The van for the test was a Fiat Ducato showed in the picture. There were in average 2 tests per day according to the scheme “High demanding task (Kart circuit) – monotonous tasks (straight and wide roads).



Figure 9: Van used for the C2 tests in Italy.

The volunteers were equipped with the wearable EEG headset, i.e. the Mindtooth Touch (<https://mindtooth-eeg.com/>), a wristband, i.e. the Empatica E4 (<https://www.empatica.com/en-eu/research/e4/>), and the eye-tracker glasses, i.e. the Tobii Pro Glasses 2 (<https://www.tobii.com/products/discontinued/tobii-pro-glasses-2>). Further sensors were placed in the van for the measurement of CO₂ concentration in the air; percentage of

relative humidity; air temperature and light intensity. A camera was placed on the internal side of the windscreen.

The van was also equipped with the "Bridgebox" developed for the detection of the driving data and their transmission through the cloud.



Figure 10: Wearing the measurement devices before the C2 tests in Italy.



Figure 11: Real-time neurophysiological parameters, specifically the EEG activity in the first 8 channels, the PPG signal (heart activity) in the 9th channel, and the EDA measurement (alias GSR, skin sweating) in the last channel, during the C2 tests in Italy.



Figure 12: High demanding task (kart circuit) during the C2 tests in Italy.

A 21" video showing the C2 test in Rome with a van is available at the following link.

<https://www.fitdrive.eu/wp-content/uploads/2023/05/cycle2-test.mp4>

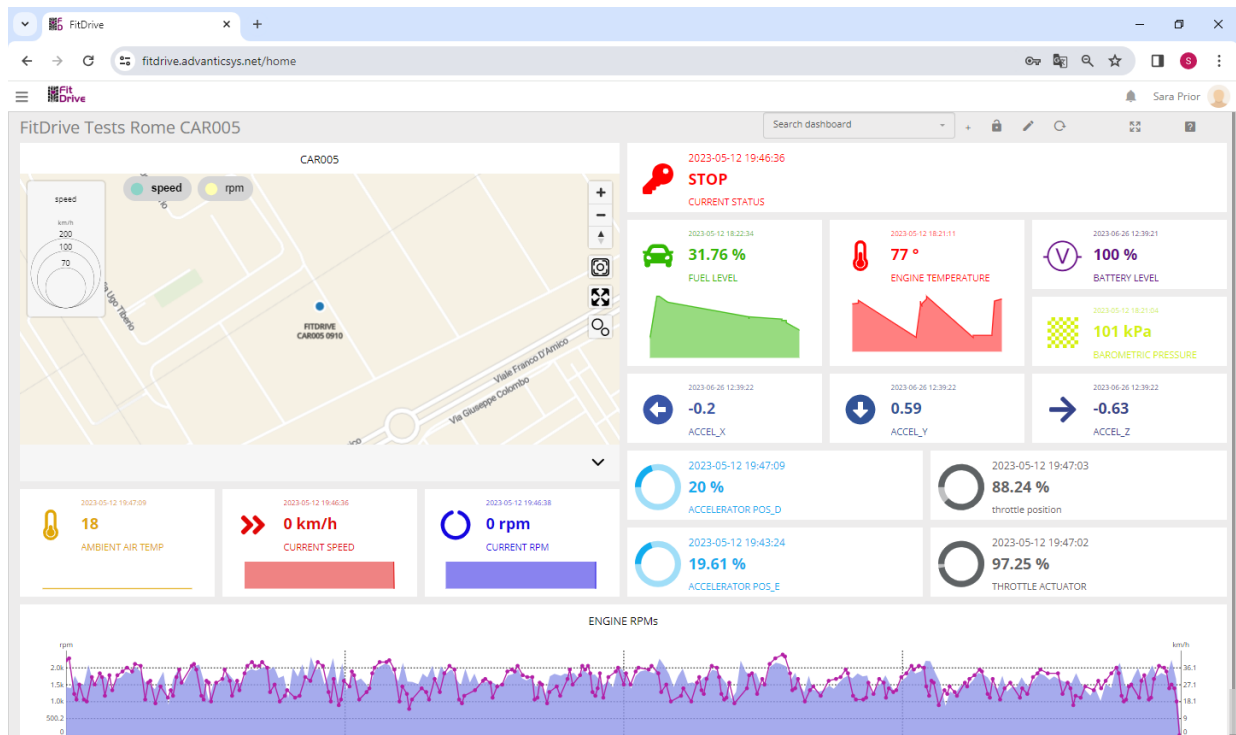

Figure 13: Dashboard with van data.



6.3. C2 test in Spain

The C2 Tests in Spain were conducted in the chosen location Villatoldanos (Leon): such tests are particularly relevant because they were carried out with a heavy vehicle and involved the use of the smart tachograph developed by Aselsan. The integration of the instruments required more time than expected, due to the first model of Truck used: due to this issue, the tests with the volunteers started at the end of October 2023, while initially it was scheduled between June and July. Part of this delay has already been recovered, since the partner MDU was able to start the analysis of the data collected from the C2 test in Italy.

The “dry run” (pre-test without volunteers) was conducted in Valladolid in June 2023, without the smart-tachograph installed.

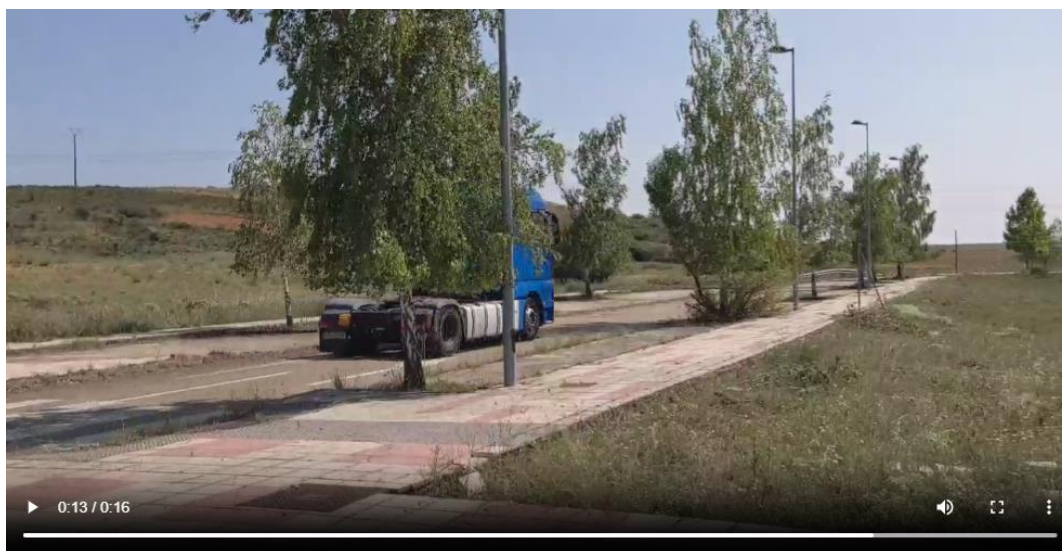

Figure 14: preliminary test in controlled environment in Spain.

A short video (16”) is available at the following link:

https://www.fitdrive.eu/wp-content/uploads/2023/06/video_2023-06-20_12-22-10-2.mp4

Some issues were experienced related to the BridgeBox compatibility (*not all vehicle data are correctly being received by the BridgeBox*), due to the fact that truck brands don’t always follow standards: they promote proprietary vehicle data systems aiming for customer subscriptions. Even if the EC is aware of this and is trying to reduce this brand-dependency, adequate standardisation and regulation/legislation are necessary: this will be reported in the next FitDrive events.

The compatibility issues implied a noticeable amount of effort (mainly from ADSYS, Aselsan, and ITCL) to find a truck model complying with the standards and then to make an adequate calibration of the devices; such efforts are summarized hereinafter:

- Renting a new truck model (MAN TGX 2015).
- Smart Tachograph calibration.
- Smart Tachograph installation with MAN workshop employees.

- BridgeBox connection & installation.
- New dry run for data collection test.
- Data analysis.
- Software modification to prioritize the “key signals” most relevant for the FitDrive purposes, in order to avoid potential overload/blocking of the CANbus.
- BridgeBox software adjustment and (truck) data validation.

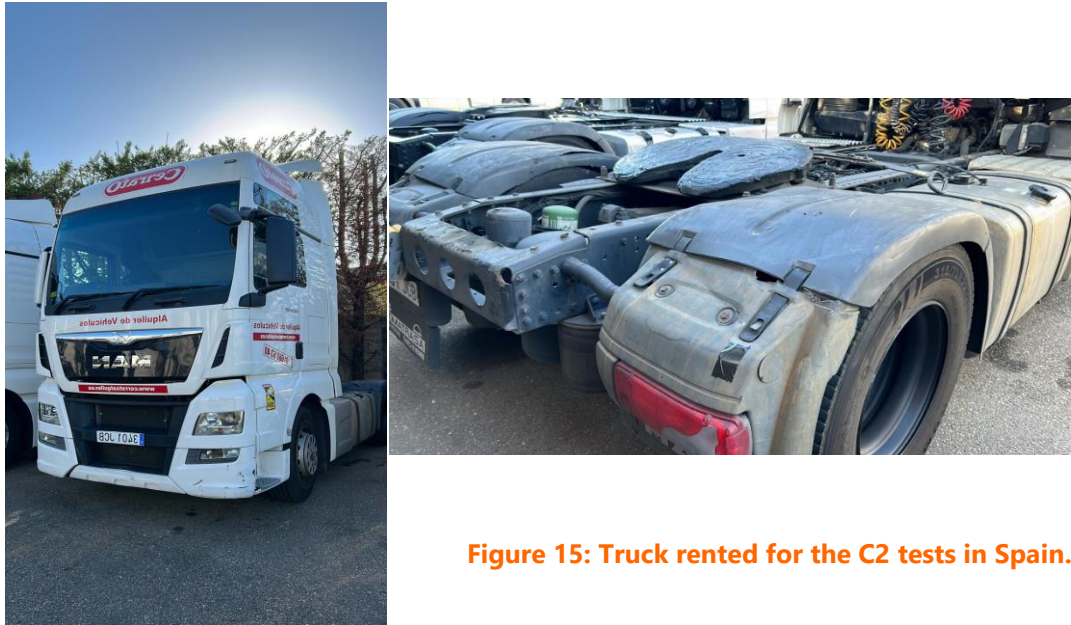

Figure 15: Truck rented for the C2 tests in Spain.

Finally, the C2 tests in Spain were conducted between the end of October and the beginning of November 2023; 8 out of 16 C1 volunteers were selected based on the quality of the data recorded during the Cycle 1. The list of the data set obtained is reported in the following, with the volunteers indicated through their anonymous code already adopted during the Cycle 1 tests.

SPAIN:

c2esuser001
c2esuser004
c2esuser005
c2esuser006
c2esuser007
c2esuser012
c2esuser013
c2esuser017
c2esuser022
c2esuser023



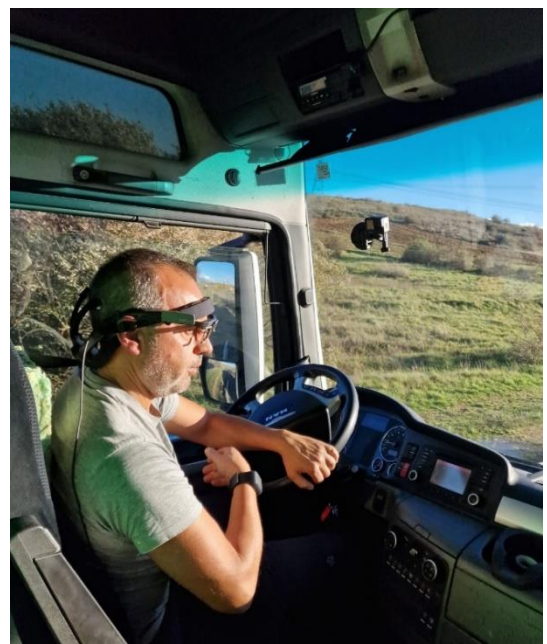

Figure 16: Volunteer driving the truck during the C2 test in Spain.







Although the Valladolid site was a “controlled environment”, the vehicle must get there starting from the laboratory where all the instruments have

been installed; in particular, the smart tachograph is not an approved device, and its installation requires the removal of the existing tachograph. Therefore, since the vehicle in its round-trip transfer would not have been formally in compliance with current legislation, the driver has been provided with a statement from the FitDrive partners which explains the need for the research project and substantial compliance, also if not formal, of the law. The declaration provided to the driver is in Spanish, while the figure shows the English version that will be used for the C3-C4 tests in Ireland.



To whom it may concern

Re: MAN TGX
Registration: [insert vehicle registration number]
VIN: [insert vehicle identification number]

The above-named vehicle has been supplied by the [insert driving school name] to the FitDrive consortium for the purpose of carrying out testing as part of the FitDrive project. This project has received funding from the European Union's Horizon 2020 research and innovation programme under grant agreement No 953432.

The testing will take place from 13th June 2023 to 30th June 2023 at Villatoldanos, León. Authorisation has been granted to use this site for the purpose of the testing by [insert name of site owner and council who granted permission]. It is necessary for the vehicle to be moved from the University of Leon to the testing site each day.

The driver of this vehicle is not engaging in "carriage by road" as defined in Article 4(1)(a) of Regulation (EU) 561/2006. This vehicle is solely being used, during the aforementioned period, for the purpose of undergoing road tests for technical development as set out in Article 3(g) of Regulation (EU) 561/2006.

The tachograph unit in this vehicle is a test unit which has not yet been type approved. The driver has available a control card herewith, which will permit interrogation of the tachograph unit, if required for enforcement purposes.

Should you have any queries or require any further clarification, please contact:

<p>Marteyn Van Gasteren R&I Manager ITCL Technology Centre Burgos +34 947 29 84 71</p>	<p>Efrén Alonso Fernández Director General Drotium Leon +34 618 456 511</p>
---	--

Thank you for your cooperation in this regard.
Yours sincerely
Kevin Hurley

FitDrive Project Officer for C2 test in Spain
European Professional Drivers Association
Dublin 11, Ireland
+ 353 87 953 5873

Figure 17: Statement given to the Truck driver explaining the use of the Smart Tachograph.

D5.3: Report on Tests in Controlled Environment

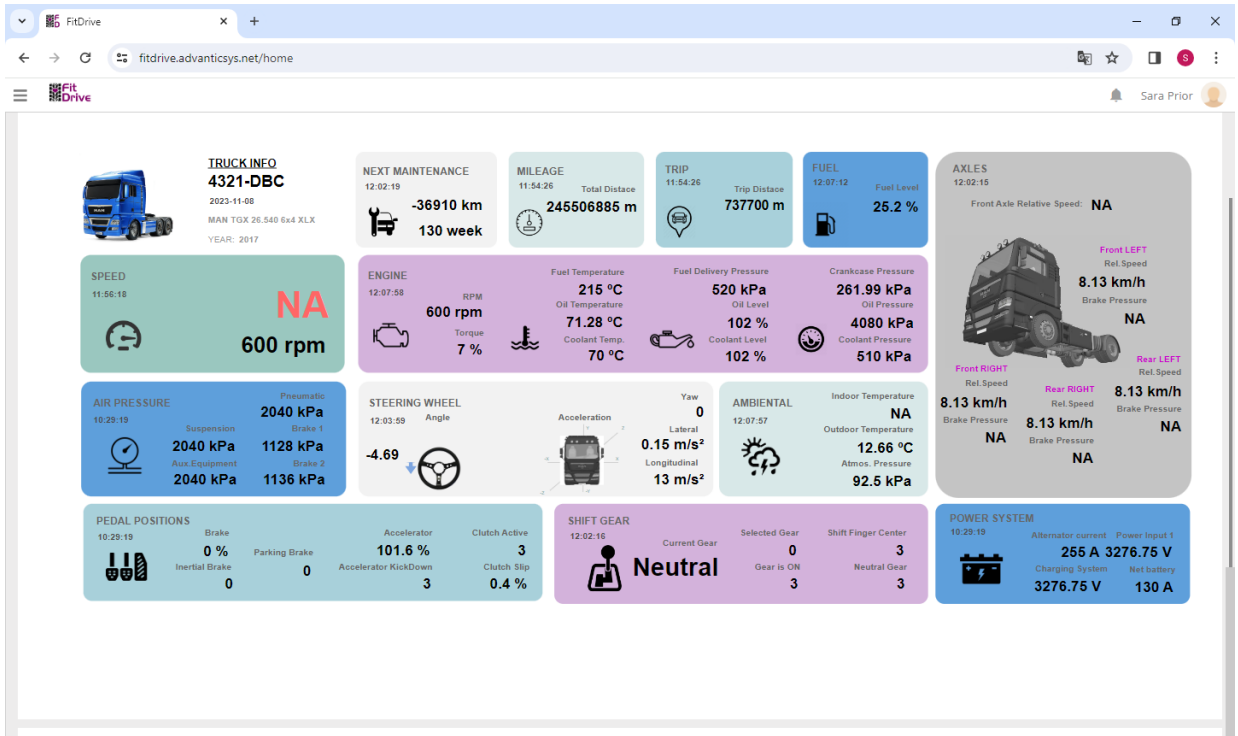

Figure 18: Dashboard controlling Trucks.

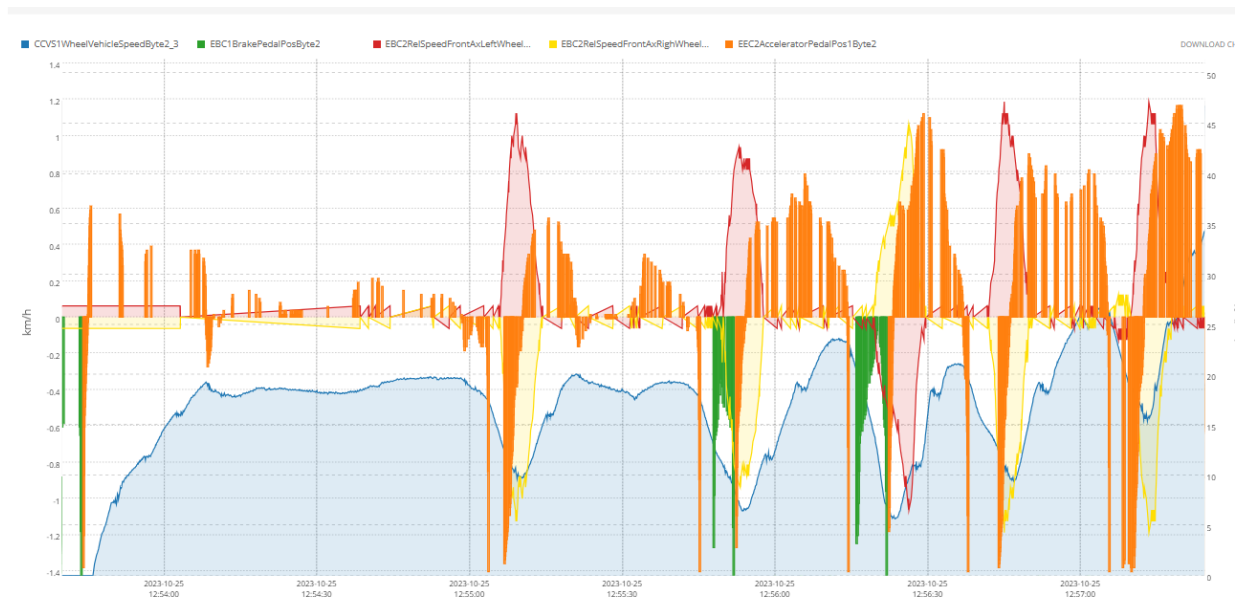

Figure 19: Example of truck data monitoring.



7. Test results

The results of the C1 tests are described in the deliverable D2.6 "*Multimodal driving behaviours analysis: impairing causes, related biomarkers and resulting driving performance*", while the C2 tests results will be described in the deliverable D3.2 "*Algorithms for Predictive Analysis and PDBM*", where also driver's behaviour predictive models developed on the basis of both the cycles, and to be used in the following steps, will be presented. Since this D5.3 is a public deliverable, while D2.6 and D3.2 are confidential ones, results cannot be exposed in this document - access to D2.6 and the D3.2 is restricted to authorized people only.



8. Conclusions

Cycle 2 tests were conducted in Italy and Spain with the planned number of volunteers, coming from a selection of the groups involved in Cycle 1. The second test cycle started in month 18 and was concluded in month 27 involving van drivers (Italy) and truck drivers (Spain), by using a rented vehicle in each location equipped with devices able to measure the drivers' neurophysiologic status and to record driving data. Due to some compatibility issues in gathering data from the rented truck (due to the fact that the truck manufacturer does not comply with the relevant EU standards) this implied additional efforts and time.

The tests were conducted in the physical location previously digitalised and implemented in the two simulators in Italy and Spain, and the vehicle data were transmitted through the FitDrive Cloud run from the offices of partner ADSYS. Even if not necessary for Cycle 2, such a transmission is crucial for Cycle 3, in order to promptly intervene in case of problems with the devices.

All the tests were successfully performed: the results are reported in the confidential deliverables D2.6 and D3.2.